



Gate Valves

ORION S.p.A. via Caboto, 8 • 34148 Trieste • Italy • tel. +39 040813204 • fax +39 040811203
e mail sales@orionvalves.com • <http://www.orionvalves.com>

ORION

Gate Valves

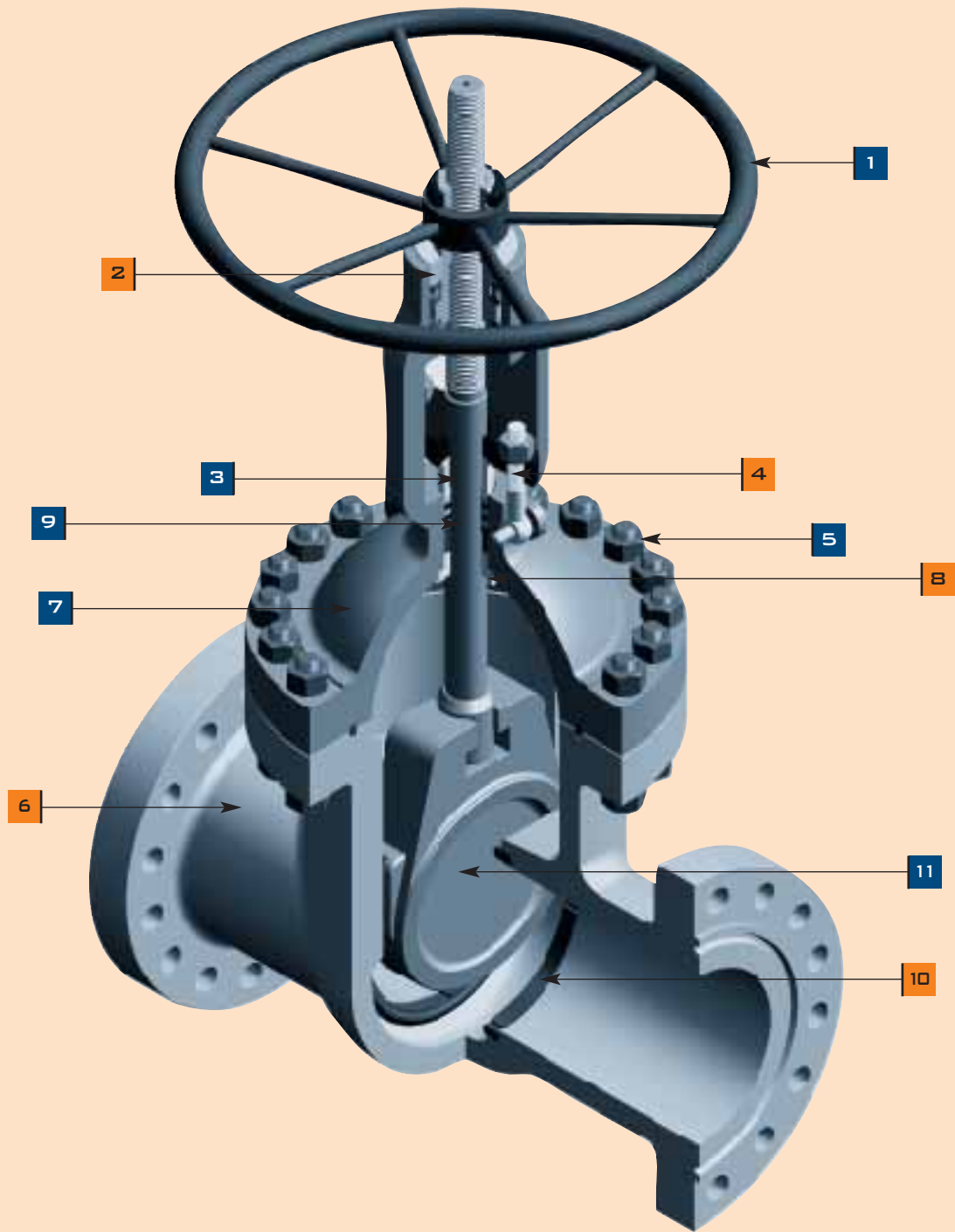

WELDED - IN SEAT RINGS



FLEX WEDGE



LANTERN RING

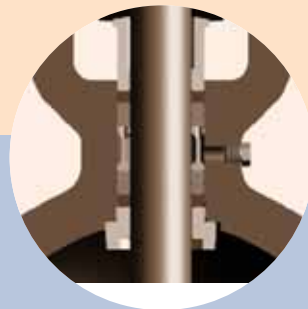

CAST STEEL, OUTSIDE SCREW AND YOKE, RISING STEM, NON-RISING HANDWHEEL, RENEWABLE SEATS, REMOVABLE YOKE SLEEVE, GLAND REPACKING UNDER PRESSURE.

- 1 HANDWHEEL.** The spoked handwheel is fabricated from steel pipe. The hub is coupled with the yoke sleeve by means of a tongue.
- 2 YOKE SLEEVE.** The yoke sleeve is made from cast aluminium bronze having high resistance to wear and a high melting point. It is designed to permit removal from the bonnet or the yoke whilst the valve is in service. Gate valves 6" class 600 and above are fitted ball thrust bearings.
- 3 GLAND AND FLANGE.** They are in forged steel and are supplied in two pieces, self-aligning design to permit the gland to descend parallel to the stem even if the eyebolts are unevenly tightened.
- 4 GLAND BOLTS AND NUTS.** The forged steel gland bolts are of the eyebolt type which can be swung outward for ease of gland repacking. They are fixed to the bonnet by hinge pins.
- 5 BONNET BOLTING.** Bonnet studs and nuts are manufactured from alloy steel to the relevant ASTM standard.
- 6 BODY.** The body is in cast steel and is carefully designed in all its details. The basic dimension, i.e. wall thickness, face to face and flanges comply with the relevant API and ANSI standards. The body-to-bonnet flange is circular, except in the Class 150 which is oval. The body-to-bonnet joint are flat face on Class 150 valves, male-and-female on Class 300 and ring joint on Class 400 and above. The body is threaded for renewable seats. Bosses are provided for drain taps or by-pass piping.
- 7 BONNET.** The bonnet is in cast steel. It is machined to accept yoke sleeve and incorporates a stuffing box dimensioned in accordance with the API standard.
- 8 BONNET BUSHING.** The bonnet bushing or backseat is in forged stainless and forms part of the trim. Special attention is given to its machining.
- 9 STEM.** The stem is in forged stainless steel and is part of the trim. The stem is provided with a T head. A ground backseat is provided to ensure a perfectly tight seal to the stuffing box when the valve is fully open. The stem is ground to minimize friction and prevent damage to gland packing. The threading is trapezoidal ACME type. Dimensions comply with the API 600 standard.
- 10 SEAT RINGS.** The rings are in forged stainless steel and are part of the trim. They are completely threaded outside and notched on their inner surface to ease installing and dismantling. Special attention is given to the sealing surface which are ground and lapped for a perfectly seal. Welded-in seat rings may be supplied upon request.
- 11 WEDGE.** The wedge is part of the trim. It is forged stainless steel for diameters up to 12" and is in cast steel for larger valves. It is normally supplied as the solid wedge type. It is connected to the stem by means of a T joint. The guides on each side of the wedge are machined. Special attention is given to the seating surfaces which are ground and lapped.

REMARKS: A lantern ring is furnished only on request, in this case the stuffing box shall be tapped and fitted with an NPS 1/4 plug.

Class ANSI 150 [PN 20]

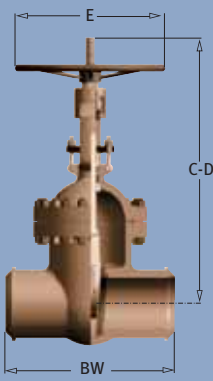
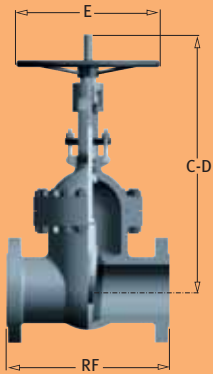

FIGURE NUMBERS
CLASS ANSI 150 - ALL SIZES
 SR 150 RFRAISED FACE
 SR 150 BWWELDING ENDS

SIZE	2"	2 1/2"	3"	4"	5"	6"	8"	10"	12"	14"
RF	177,8	190,5	203,2	228,6	254,0	266,7	292,1	330,2	355,6	381,0
BW	215,9	241,3	282,6	304,8	381,0	403,2	419,1	457,2	501,7	571,5
C-closed	357,0	415,0	445,0	556,0	615,0	712,0	862,0	1.020,0	1.178,0	1.318,0
D-open	417,0	490,0	530,0	671,0	755,0	877,0	1.082,0	1.290,0	1.498,0	1.676,0
E	204,0	204,0	254,0	305,0	305,0	356,0	406,0	457,0	502,0	610,0

SIZE	16"	18"	20"	22"	24"	26"	28"	30"	32"	34"
RF	406,4	431,8	457,2	482,6	508,0	558,8	609,6	609,6	660,4	711,2
BW	609,6	660,4	711,2	762,0	812,8	863,6	914,4	914,4	965,2	1.016,0
C-closed	1.440,0	1.608,0	1.768,0	1.940,0	2.064,0	2.220,0	2.375,0	2.518,0	2.620,0	2.690,0
D-open	1.850,0	2.069,0	2.271,0	2.492,0	2.680,0	2.876,0	3.092,0	3.281,0	3.435,0	3.555,0
E	610,0	-	-	-	-	-	-	-	-	-

SIZE	36"	40"	42"	48"	52"	54"	56"	60"	66"
RF	711,2	762,0	787,4	863,6	1.106,0	1.066,8	1.054,6	1.119,1	1.270,0
BW	1.016,0	1.066,8	1.066,8	-	-	-	-	-	-
C-closed	2.970,0	3.228,0	3.372,0	3.702,0	4.127,0	4.305,0	4.414,7	4.711,5	5.156,0
D-open	3.876,0	4.228,0	4.415,0	4.912,0	5.462,0	5.693,0	5.830,5	6.227,6	6.823,0
E	-	-	-	-	-	-	-	-	-

Class ANSI 300 [PN 50]

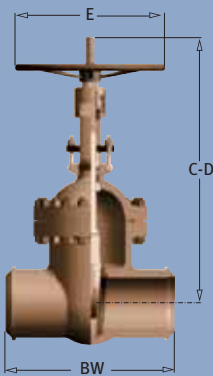
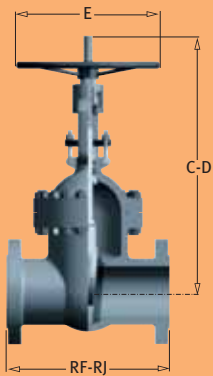

FIGURE NUMBERS
CLASS ANSI 300 - ALL SIZES
 SR 300 RFRAISED FACE
 SR 300 BWWELDING ENDS
 SR 300 RJRING JOINT

SIZE	2"	2 1/2"	3"	4"	5"	6"	8"	10"	12"	14"
RF	215,9	241,3	282,6	304,8	381,0	403,2	419,1	457,2	501,7	762,0
BW	231,8	257,2	298,5	320,7	396,9	419,1	435,0	473,1	517,5	777,9
C-closed	370,0	430,0	445,0	556,0	615,0	712,0	890,0	1.069,0	1.245,0	1.325,0
D-open	430,0	510,0	530,0	671,0	755,0	877,0	1.110,0	1.339,0	1.580,0	1.685,0
E	204,0	204,0	254,0	305,0	305,0	406,0	457,0	457,0	-	-

SIZE	16"	18"	20"	22"	24"	26"	28"	30"	32"	36"
RF	838,2	914,4	990,6	1.092,2	1.143,3	1.346,2	1.346,2	1.397,0	1.524,0	1.727,2
BW	854,1	930,3	1.009,7	1.114,4	1.165,2	1.371,6	1.371,6	1.422,4	1.552,6	1.755,7
C-closed	1.480,0	1.620,0	1.796,0	1.948,0	2.122,0	2.430,0	2.430,0	2.596,0	2.705,0	2.970,0
D-open	1.890,0	2.069,0	2.287,0	2.500,0	2.729,0	3.146,0	3.146,0	3.355,0	3.515,0	3.885,0
E	-	-	-	-	-	-	-	-	-	-

SIZE	42"	48"	54"	60"
RF	1.981,2	2.235,2	2.387,6	2.540,0
BW	-	-	-	-
C-closed	3.454,0	3.870,0	4.330,0	4.810,0
D-open	4.511,0	5.100,0	5.700,0	6.330,0
E	-	-	-	-

N.B. All dimensions are given in millimeters.

Class ANSI 400 [PN 68]

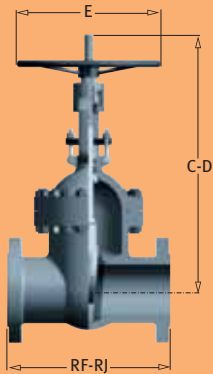

FIGURE NUMBERS

CLASS ANSI 400 - ALL SIZES

SR 400 RFRAISED FACE

SR 400 BWWELDING ENDS

SR 400 RJRING JOINT

SIZE	2"	2 1/2"	3"	4"	5"	6"	8"	10"	12"	14"
RF-BW	292,1	330,2	355,6	406,4	457,2	495,3	596,9	673,1	762,0	825,5
RJ	295,3	333,4	358,8	409,6	460,4	498,5	600,1	676,3	765,2	828,7
C-closed	371,0	448,0	515,0	618,0	715,0	740,0	920,0	1.225,0	1.318,0	1.420,0
D-open	431,0	538,0	620,0	745,0	855,0	888,0	1.140,0	1.505,0	1.644,0	1.780,0
E	204,0	254,0	305,0	356,0	406,0	457,0	457,0	-	-	-

SIZE	16"	18"	20"	22"	24"	26"	30"	36"	42"	48"
RF-BW	901,7	977,9	1.054,1	1.143,0	1.231,9	1.308,1	1.524,0	1.879,6	2.184,4	2.387,6
RJ	904,9	981,1	1.060,5	1.152,5	1.241,4	1.320,8	1.536,7	1.895,5	-	-
C-closed	1.540,0	1.680,0	2.220,0	2.340,0	2.500,0	2.550,0	2.740,0	3.180,0	3.610,0	4.070,0
D-open	1.956,0	2.133,0	2.700,0	2.895,0	3.100,0	3.250,0	3.490,0	4.080,0	4.650,0	5.260,0
E	-	-	-	-	-	-	-	-	-	-



Class ANSI 600 [PN 100]

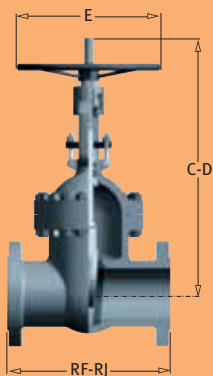

FIGURE NUMBERS

CLASS ANSI 600 - ALL SIZES

SR 600 RFRAISED FACE

SR 600 BWWELDING ENDS

SR 600 RJRING JOINT

SIZE	2"	2 1/2"	3"	4"	5"	6"	8"	10"	12"	14"
RF-BW	292,1	330,2	355,6	431,8	508,0	558,8	660,4	787,4	838,2	889,0
RJ	12,3	333,4	358,8	435,0	511,2	562,0	663,6	790,6	841,4	892,2
C-closed	371,0	448,0	515,0	600,0	665,0	840,0	925,0	1.120,0	1.318,0	1.429,0
D-open	431,0	528,0	620,0	720,0	800,0	1.003,0	1.138,0	1.400,0	1.644,0	1.781,0
E	204,0	254,0	305,0	356,0	406,0	502,0	-	-	-	-

SIZE	16"	18"	20"	22"	24"	26"	30"	36"	42"	48"
RF-BW	990,6	1.092,2	1.193,8	1.295,4	1.397,0	1.447,8	1.651,0	2.082,8	2.438,4	2.540,0
RJ	993,8	1.095,4	1.200,2	1.304,9	1.406,5	1.460,5	1.663,7	2.098,6	-	-
C-closed	1.588,0	1.700,0	1.775,0	1.960,0	2.183,0	2.380,0	2.698,0	3.168,0	3.690,0	4.100,0
D-open	1.998,0	2.138,0	2.253,0	2.495,0	2.771,0	3.026,0	3.478,0	4.078,0	4.720,0	5.280,0
E	-	-	-	-	-	-	-	-	-	-

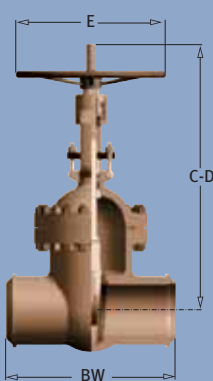

SIZE	52"	54"	56"	60"
RF-BW	2.805,4	2.904,7	3.004,0	3.202,6
C-closed	4.443,4	4.603,7	4.763,9	5.084,3
D-open	5.722,8	5.931,5	6.140,2	6.557,6
E	-	-	-	-

Class ANSI 900 [PN 150]

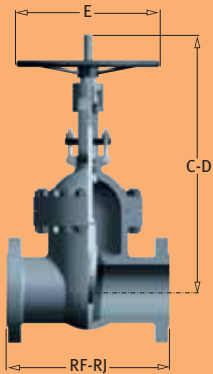

FIGURE NUMBERS

CLASS ANSI 900 - ALL SIZES

SR 900 RFRAISED FACE

SR 900 BWWELDING ENDS

SR 900 RJRING JOINT

SIZE	2"	2 1/2"	3"	4"	6"	8"	10"	12"	14"	16"
RF-BW	368,3	419,1	381,0	457,2	609,6	736,6	838,2	965,2	1.028,7	1.130,3
RJ	371,5	422,3	384,2	460,4	612,8	739,8	841,4	968,4	1.038,2	1.139,8
C-closed	505,0	530,0	530,0	655,0	875,0	1.070,0	1.180,0	1.305,0	1.400,0	1.518,0
D-open	575,0	615,0	618,0	780,0	1.040,0	1.305,0	1.440,0	1.607,0	1.746,0	1.901,0
E	305,0	356,0	356,0	406,0	-	-	-	-	-	-

SIZE	18"	20"	24"	30"	36"	40"	42"	48"	52"
RF-BW	1.219,2	1.320,8	1.549,4	1.930,4	2.082,8	2.380,1	2.484,8	2.799,1	3.008,6
RJ	1.231,9	1.333,5	1.568,5	1.952,6	2.111,4				
C-closed	1.730,0	1.896,0	2.260,0	2.750,0	3.250,0	3.527,9	3.687,4	4.165,9	4.484,9
D-open	2.160,0	2.370,0	2.830,0	3.455,0	4.200,0	4.506,2	4.713,8	5.336,6	5.751,8
E	-	-	-	-	-	-	-	-	-

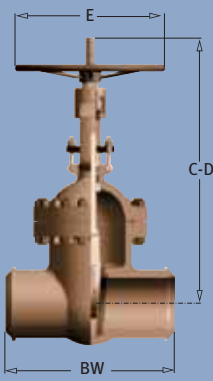

Class ANSI 1500 [PN 250]

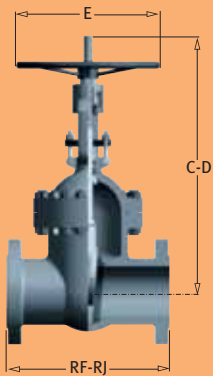

FIGURE NUMBERS

CLASS ANSI 1500 - ALL SIZES

SR 1500 RFRAISED FACE

SR 1500 BWWELDING ENDS

SR 1500 RJRING JOINT

SIZE	2"	2 1/2"	3"	4"	6"	8"	10"	12"	14"	16"
RF-BW	368,3	419,1	469,9	546,1	704,9	831,9	990,6	1.130,3	1.257,3	1.384,3
RJ	371,5	422,3	473,1	549,3	711,2	841,4	1.001,1	1.146,2	1.276,4	1.406,5
C-closed	505,0	530,0	557,0	715,0	915,0	1.065,0	1.270,0	1.318,0	1.450,0	1.565,0
D-open	575,0	615,0	636,0	845,0	1.085,0	1.263,0	1.515,0	1.604,0	1.760,0	1.925,0
E	305,0	356,0	406,0	457,0	-	-	-	-	-	-

SIZE	18"	20"	24"	30"	32"	34"	36"	40"	42"
RF-BW	1.536,7	1.663,7	1.943,1	2.383,3	2.524,9	2.666,5	2.808,1	3.091,3	3.232,9
RJ	1.558,9	1.685,9	1.971,7	2.286,0					
C-closed	1.760,0	2.075,0	2.330,0	2.940,0	2.963,5	3.126,1	3.288,6	3.613,7	3.776,2
D-open	2.158,0	2.540,0	2.860,0	3.605,0	3.661,6	3.865,7	4.069,9	4.478,1	4.682,2
E	-	-	-	-	-	-	-	-	-



Class ANSI 2500 [PN 420]

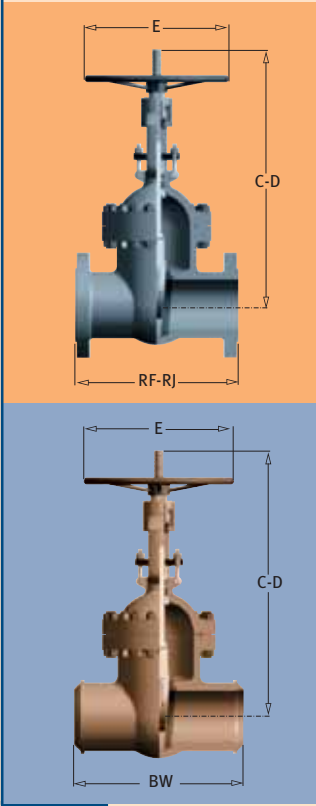

FIGURE NUMBERS

CLASS ANSI 2500 - ALL SIZES

SR 2500 RFRAISED FACE

SR 2500 BWWELDING ENDS

SR 2500 RJRING JOINT

SIZE	2"	2 1/2"	3"	4"	6"	8"	10"	12"	14"	16"
RF-BW	450,9	508,0	577,9	673,1	914,4	1.022,3	1.270,0	1.422,4	1.636,5	1.830,4
RJ	454,0	514,4	584,2	682,6	927,1	1.038,2	1.292,2	1.444,6		
C-closed	504,0	554,0	620,0	716,0	1.070,0	1.386,0	1.502,0	1.639,0	1.983,0	2.227,1
D-open	568,0	620,0	700,0	816,0	1.215,0	1.556,0	1.717,0	1.889,0	2.271,9	2.553,9
E	300,0	350,0	400,0	450,0	-	-	-	-	-	-

SIZE	18"	20"	24"	26"
RF-BW	2.024,3	2.218,2	2.606,0	2.799,8
C-closed	2.471,2	2.715,3	3.203,6	3.447,7
D-open	2.835,9	3.117,9	3.681,9	3.963,9
E	-	-	-	-

Note: For sizes and pressure classes not mentioned in the above tables please contact Orion.

